



Powers™ Controls

656 Powermite Valve with 3-inch Top Rebuilding

Description This Technical Bulletin describes the recommended method of rebuilding the 656 Powermite valve.

Warning/Caution Notations

WARNING		Personal injury/loss of life may occur if you do not perform a procedure as specified.
CAUTION		Equipment damage, or loss of data may occur if you do not perform a procedure as specified

Product Numbers

Table 1.

VP 656 Valve	Rebuild/Repack Kit	Repacking Kit
1/2 NO Cv 0.5 Spring Range 3-8 psi	656-769	656-601
1/2 NO Cv 0.9 & 2.1 Spring Range 3-8 psi	656-761	
1/2 NO Cv 0.5 & 2.1 Spring Range 5-10 psi	656-768	
3/4 NO Cv 4.6	656-762	
1/2 NC Model 1 & 2	656-763	
1/2 NC Model 3	656-014	
3/W Flared Cv 1.5	656-764	
3/W Flared Cv 2.5	656-765	
3/W Screwed	656-766	
656-0006 Discontinued	656-767	



WARNING:

Shut off medium and remove the valve from the line before beginning the rebuilding.

Diaphragm and Quad Ring Replacement

1. Remove four housing screws and remove the upper housing.
2. Remove the diaphragm and the piston cup.
3. Press down on the piston plate to remove the E-ring.

(See Figure 1)

Diaphragm and Quad Ring Replacement, Continued



CAUTION:

Hold the piston plate securely. Removing the E-ring releases the tension on the piston plate and spring.

4. Use a screwdriver to release the E-ring from the groove in the stem.
5. Remove the washer and piston plate from the valve stem and lift out the valve spring and the spring washer (10 to 15 psi spring only).
6. Remove the push-on retaining ring with a screwdriver or long nose pliers.
7. Remove the quad ring retainer for access to the upper quad ring seal.
8. Move the valve stem up and down a few times before removing the quad ring. You may need a pick to dislodge the quad ring from the valve bonnet.

NOTE: Siemens Building Technologies does not recommend field replacement of the lower quad ring, the lower quad ring retainer, and spring.

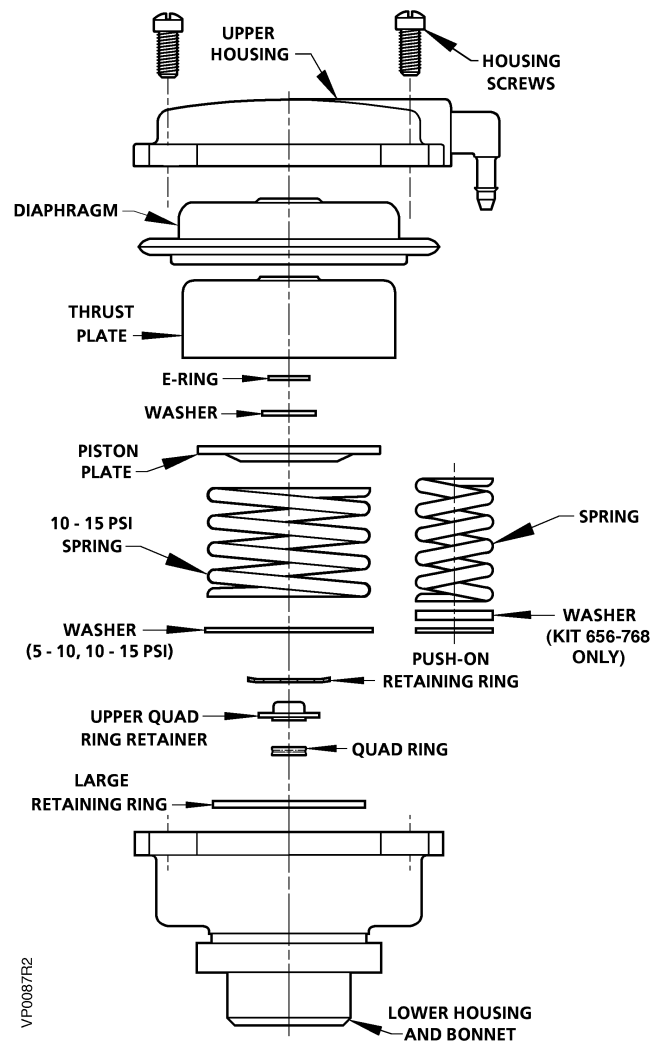

Figure 1. Actuator Assembly for Diaphragm and Quad Ring Replacement.

Diaphragm and Quad Ring Replacement, Continued

9. Before installing the new quad ring, clean the stem and the quad ring recess to remove any foreign matter. Apply a light coating of silicone grease to the valve stem, bonnet chamber, and quad ring.
10. Place the new quad ring in place and reinstall quad ring retainer over new seal with the shorter portion of the retainer next to the quad ring.
11. A new push-on retaining ring must be used because the old ring is usually damaged when it is removed. Place a little silicone grease on the end of a piece of 5/8-inch OD copper tubing to hold the ring. See Figure 2. Use the tubing to press the ring into place.

NOTE: The bent edges of the retaining ring must face the tubing.

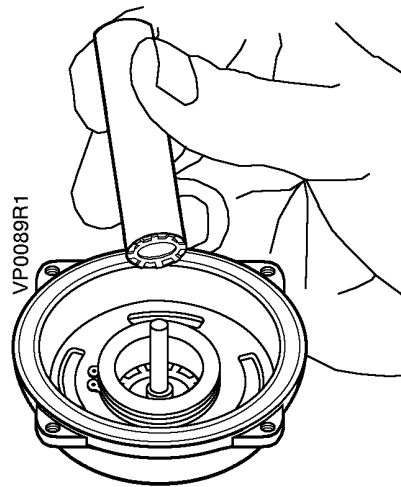

Figure 2. Replacing the Push-on Retaining Ring.

12. Slip the spring washer and spring over the stem. Place the piston plate with the cup side up over the spring. Press down on the piston plate to compress the spring. Clip the E-ring into the groove in the stem. Place the piston cup over the piston plate.
13. Replace the diaphragm with the word "Top" and the letter "A" on the outside facing the upper housing. Diaphragm can be turned inside out to do this.
14. Place upper housing over the lower housing and fasten with the housing screws.

Disc Replacement

Normally Open Valves (See Figure 3)

1. Loosen and unscrew the bonnet from the valve body.
2. Holding the disc holder securely with pliers, use a hex Allen wrench to unscrew the throttling nut from the stem assembly.
3. Remove the disc from the stem assembly and replace with new disc.
4. Return the throttling nut to the stem assembly.
5. Remove and replace the O-ring, if present. Apply silicone grease to the O-ring.
6. Thread bonnet onto the valve body and tighten it.

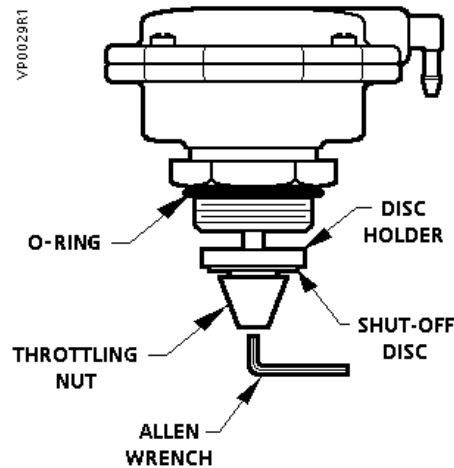

Figure 3. Normally Open Valve Disc Replacement.

Normally Closed Valves Model 1

1. Unscrew the valve cap from the bottom of the valve body. Remove the valve spring and throttling nut assembly.
2. With a 7/16-inch wrench hold the disc holder guide, and with a wide blade screwdriver in the throttling nut slot, separate these parts and remove the disc.
3. Replace the disc in the disc holder. Tighten the throttling nut while holding the disc holder guide.
4. Place the throttling plug assembly into the valve body and tighten the valve cap.

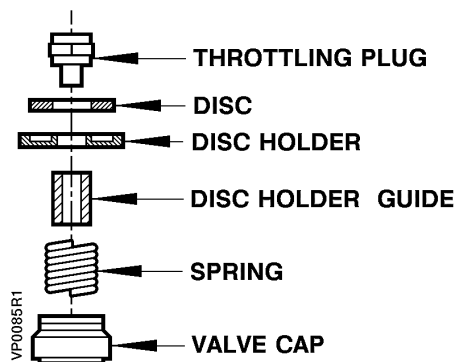

Figure 4. Normally Closed Valve Disc Replacement Model 1.

Disc Replacement, Continued

Normally Closed Valves Model 3

1. Loosen and unscrew the cap from the bottom of the valve body. If the stem assembly is not easily accessible, put 20 psi (138 kPa) air pressure on the valve actuator.
2. Use a hex Allen wrench on the bottom of the valve stem to prevent it from turning while using an open-end wrench to loosen and unscrew the retaining nut from the stem assembly.
3. Remove the washer, the disc holder, and the disc.
4. Replace the disc in the disc holder. Replace the washer and tighten the retaining nut onto the stem assembly.
5. If present, replace the O-ring. Apply a small amount of silicone grease to the O-ring.
6. Tighten the valve cap onto the valve body.

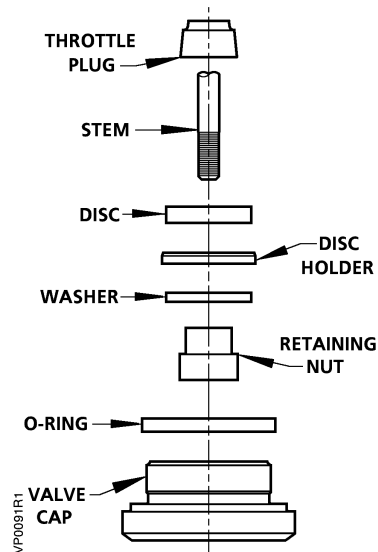

Figure 5. Normally Closed Valve Disc Replacement Model 3.

Throttling Plug Replacement for Water Mix Flared End Valves (See Figure 7)

1. Loosen and unscrew the valve cap using a 1-13/16 inch wrench.
2. Use the special seat removal tool (Figure 6) held with a 7/8-inch wrench to unscrew and remove the valve seat retainer. The lower seat and gasket will drop out.

NOTE: The seat removal tool must be made locally. It is not offered as an orderable part.

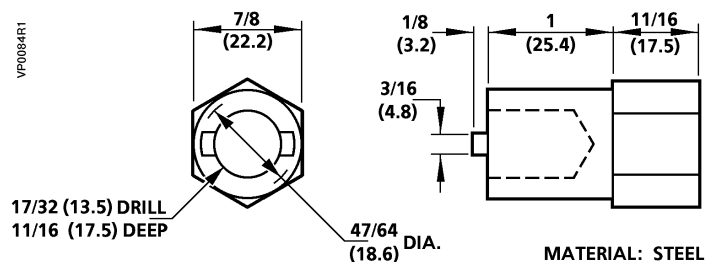

Figure 6. Seat Removal Tool. Dimensions in Inches (Millimeters).

Throttling Plug Replacement for Water Mix Flared End Valves, Continued

3. To disassemble the stem assembly, put 20 psi (138 kPa) air pressure on the valve actuator. Hold the stem with a 3/32-inch hex Allen wrench and use a 1/4-inch wrench to unscrew the throttling plug locknut from the stem assembly. Note the orientation of the plug before removing it because the replacement plug must be installed with the same orientation.
4. Separate the throttling plug from the stem. Replace with new plug.
5. Put 20 psi (138 kPa) air pressure in the actuator. Insert the allen wrench in the end of the stem and while holding it steady, tighten the locknut against the throttling plug. Be careful not to twist the stem.
6. When assembling the lower seat, assemble gasket, lower seat, and seat retainer into the valve to within one turn of being tight using the special seat removal tool.
7. Apply 20 psi (138 kPa) air pressure to the top of the valve. Turn the seat retainer until it is tight. The plug is now making contact with the lower seat.
8. Tighten the valve cap to the valve body.

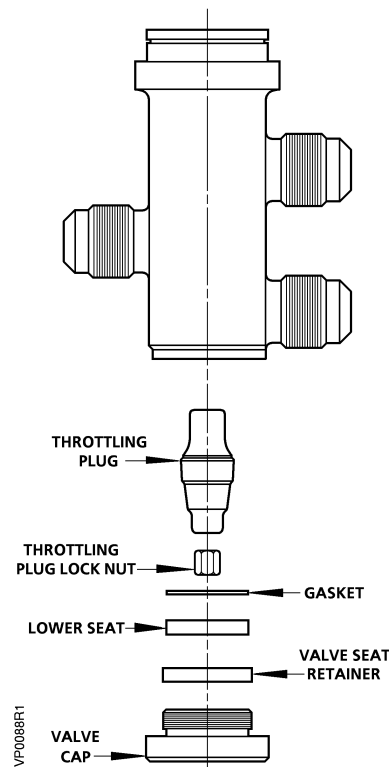

Figure 7. Water Mix Flared-End Throttling Plug Replacement.

Water Mix Screwed End Valves

1. Loosen and unscrew the valve seat (bottom port) from the valve body. If the stem assembly is not easily accessible, put 20 psi (138 kPa) air pressure on the valve actuator.
2. Use a 3/32-inch hex Allen wrench in the bottom of the valve stem to prevent it from turning while using a 3/8-inch wrench to loosen and unscrew the disc retaining nut from the stem assembly.
3. Separate the stem collar and disc holder and both discs from the stem assembly.
4. Remove and replace the discs.
5. Slide the disc holder with the new discs, and stem collar over the stem.
6. Tighten the disc retaining nut to the stem assembly.
7. Replace the O-ring if damaged. Apply a small amount of silicone grease to the O-ring.
8. Tighten the valve bottom port to the valve body.

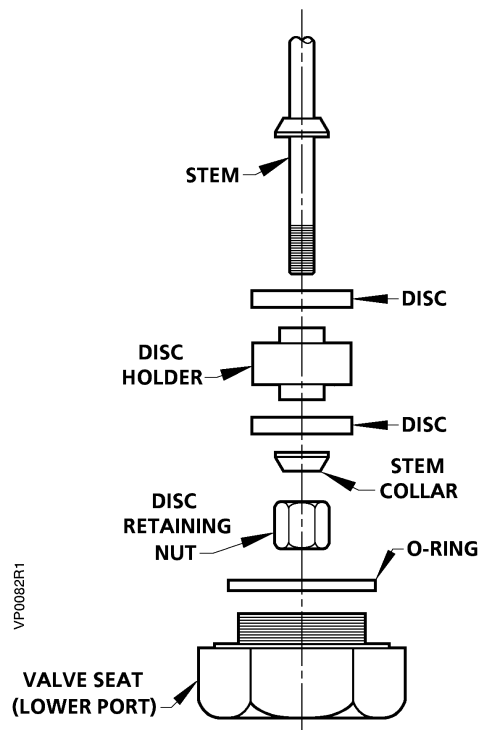

Figure 8. Water Mix Screwed-end Valve Disc Replacement.

Information in this publication is based on current specifications. The company reserves the right to make changes in specifications and models as design improvements are introduced. Powers is a registered trademark of Siemens Industry, Inc. Product or company names mentioned herein may be the trademarks of their respective owners. © 2005 Siemens Industry, Inc.